

Quick-Lift Arm Torque

QL AT 125i

Intelligent lifting device which meets the highest standards of ergonomics, working environment, safety and efficiency.

Provides possibility to effortlessly handle eccentric loads.

Easy to use, thanks to outstanding responsiveness, regardless of load weight.

Exceptional safety is achieved using our intelligent control systems.

High cost efficiency through high reliability, increased productivity and long durability.

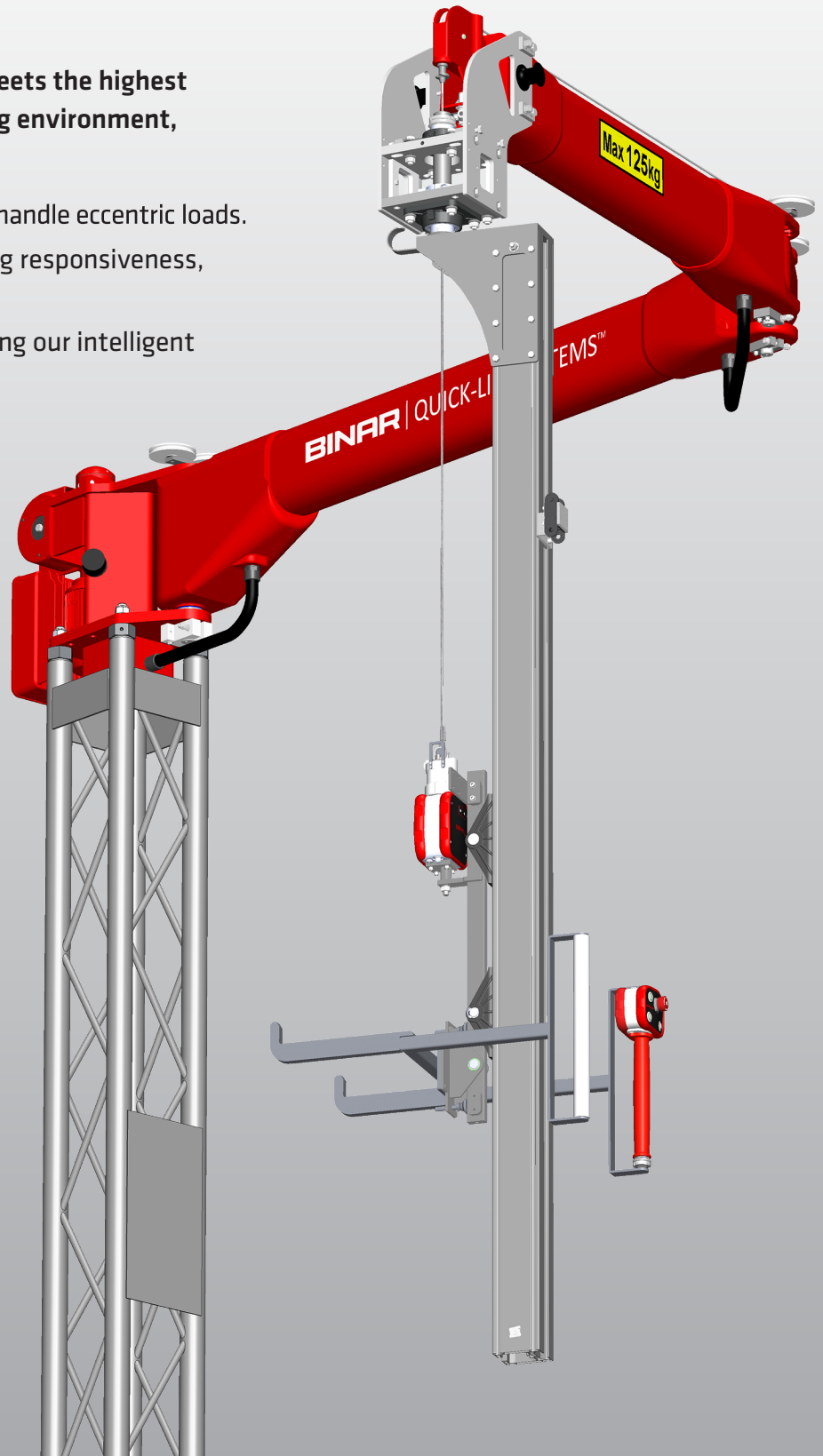

BINAR

Improving your productivity

Quick-Lift Arm Torque QL AT 125i

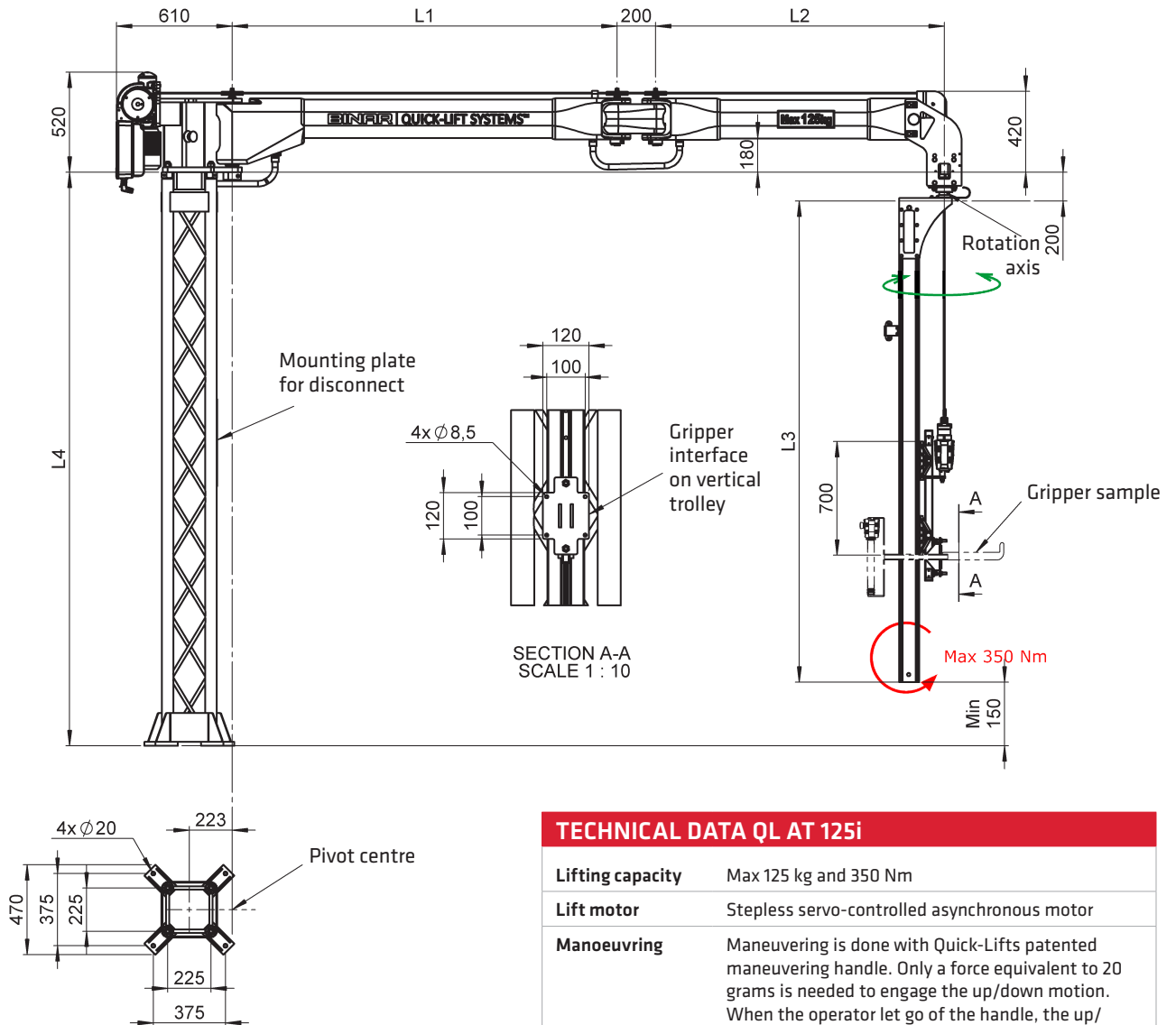

TECHNICAL DATA QL AT 125i

Lifting capacity	Max 125 kg and 350 Nm
Lift motor	Stepless servo-controlled asynchronous motor
Manoeuvring	Maneuvering is done with Quick-Lifts patented maneuvering handle. Only a force equivalent to 20 grams is needed to engage the up/down motion. When the operator let go of the handle, the up/down motion is immediately stopped.
Power supply	230V, 50-60 Hz, 1-phase with ground protection, 10A
Stroke length	Max Stroke length= L3-700 mm L3max=L4-200mm-150mm
Hinged arm	Made in painted aluminum profiles, and vertical profiles in anodized aluminum.
Suspension	Floor pillar in painted steel with standard height of 3 m. Optional pillar height up to 5 m depending on customers need.
Gripping device	Grippers are designed to fit customers need. Intelligent I/O signals are available for optimum functionality.

Binar Quick-Lift Systems AB disclaims responsibility for any errors or incomplete information in the published material and reserves the right to make changes.

KUNDEL Industries

1510 Ridge Road • Vienna OH 44473 • US
 ph +1 (330) 259-9009 • fax +1 (330) 259-9001
 sales@quickliftsystems.com • www.quickliftsystems.com

2014-09-17 eng 1.02-US • www.binar.se

BINAR
 Improving your productivity